

BMS Series

High speed response type with built-in output protection circuit

■ Features

- Built-in reverse power polarity protection and overcurrent protection circuit.
- High speed response : Under 1ms
- Light ON/Dark ON mode selectable by control wire.
- Built-in the sensitivity adjustment VR.
(Except for transmitted beam type)



(MS-2) (MS-5)

※MS-5 is optional.

! Please read "Caution for your safety" in operation manual before using.



■ Specifications

Model	BMS5M-TDT	BMS2M-MDT	BMS300-DDT
	BMS5M-TDT-P	BMS2M-MDT-P	BMS300-DDT-P
Sensing type	Transmitted beam	Retroreflective	Diffuse reflective
Sensing distance	5m	(*1) 0.1 ~ 2m	(*2) 300mm
Sensing target	Opaque materials of min. ϕ 10mm	Opaque materials of min. ϕ 60mm	Transparent, Translucent, Opaque materials
Hysteresis	—————		Max. 20% at rated setting distance
Response time	Max. 1ms		
Power supply	12~24VDC \pm 10% (Ripple P-P : Max. 10%)		
Current consumption	Max. 50mA	Max. 45mA	
Light source	Infrared LED(modulated)		
Sensitivity adjustment	—————	Adjustable VR	
Operation mode	Light ON, Dark ON selectable by control wire		
Control output	<ul style="list-style-type: none"> ● NPN open collector output \Rightarrow Load voltage : Max. 30VDC, Load current : Max. 200mA, Residual voltage: Max. 1V ● PNP open collector output \Rightarrow Output voltage : Min. (Power supply-2.5)V, Load current : Max. 200mA 		
Protection circuit	Reverse polarity protection, Short-circuit protection		
Indicator	Operation indicator : Red LED, Power indicator : Red LED(BMS5M-TDT1)		
Connection	Outgoing cable		
Insulation resistance	Min. 20M Ω (at 500VDC)		
Noise strength	\pm 240V the square wave noise(pulse width:1 μ s) by the noise simulator		
Dielectric strength	1000VAC 50/60Hz for 1minute		
Vibration	1.5mm amplitude at frequency of 10 ~ 55Hz in each of X, Y, Z directions for 2 hours		
Shock	500m/s ² (50G) in X, Y, Z directions for 3 times		
Ambient illumination	Sunlight : Max. 11,000lx, Incandescent lamp : Max. 3,000lx (Receiving illumination)		
Ambient temperature	-10 ~ +60 $^{\circ}$ C (at non-freezing stausts), Storage : -25 ~ +70 $^{\circ}$ C		
Ambient humidity	35 ~ 85%RH, Storage : 35 ~ 85%RH		
Material	Case:ABS, Lens:Acrylic(Retroreflective:PC)		
Cable	4P, ϕ 5mm, Length : 2m(Emitter of transmitted beam type: 2P, ϕ 5mm, length:2m)		
Accessories	Individual	—————	Reflector (MS-2), Adjustment Driver
	Common	Fixing bracket, Bolts/Nuts	
Approval	CE		
Unit weight	Approx. 180g	Approx. 110g	Approx. 100g

※(*1) Sensing distance between sensor and MS-2, it is the same when using MS-5 and transmitted beam it is able to sense under 0.1m

※(*2) It is for Non-glossy white paper(100 \times 100mm)

Side Sensing Type with Built-in Amplifier

Feature data

○ Transmitted beam

● **BMS5M-TDT** ● **BMS5M-TDT-P**

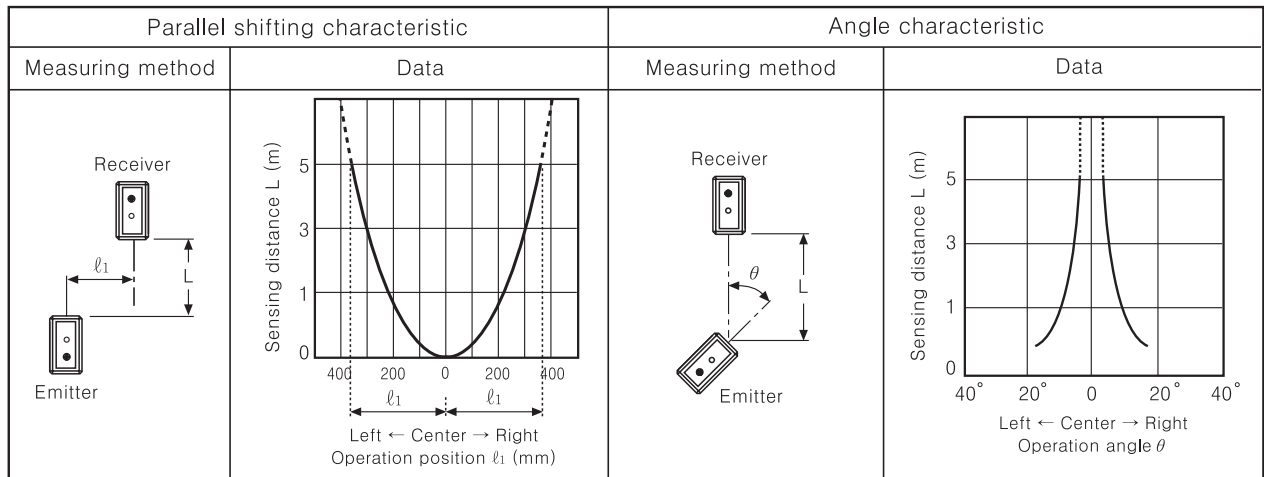

○ Retroreflective

● **BMS2M-MDT** ● **BMS2M-MDT-P**

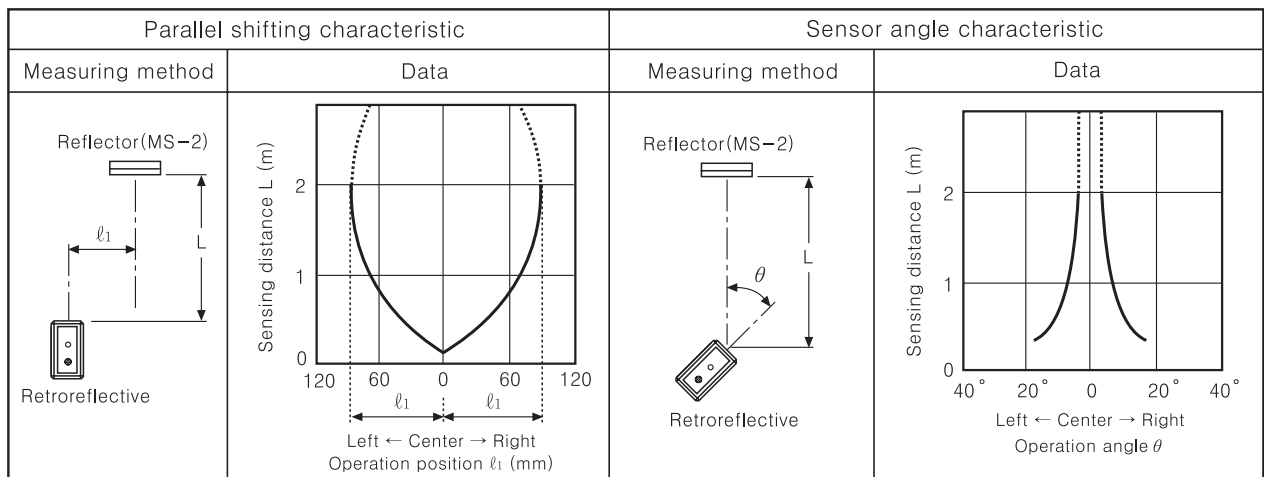

○ Retroreflective

● **BMS2M-MDT**
● **BMS2M-MDT-P**

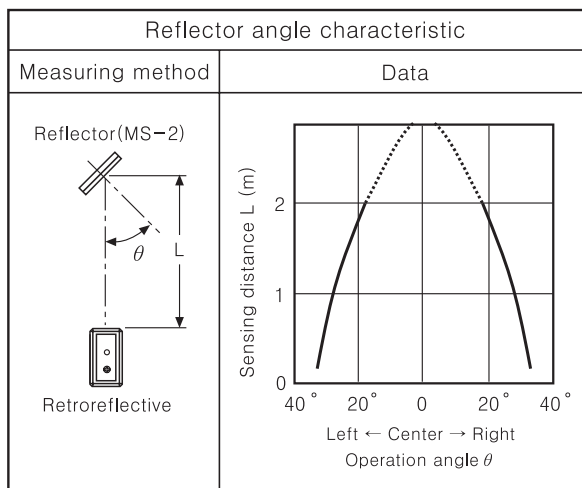

○ Diffuse reflective

● **BMS300-DDT**
● **BMS300-DDT-P**

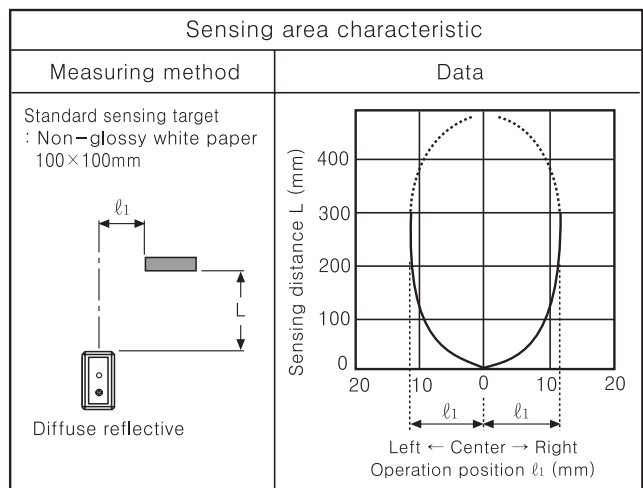

(A) Counter

(B) Timer

(C) Temp. controller

(D) Power controller

(E) Panel meter

(F) Tacho/Speed/Pulse meter

(G) Display unit

(H) Sensor controller

(I) Switching power supply

(J) Proximity sensor

(K) Photo electric sensor

(L) Pressure sensor

(M) Rotary encoder

(N) Stepping motor & Driver & Controller

(O) Graphic panel

(P) Production stoppage models & replacement

BMS Series

Control output diagram

●NPN open collector output

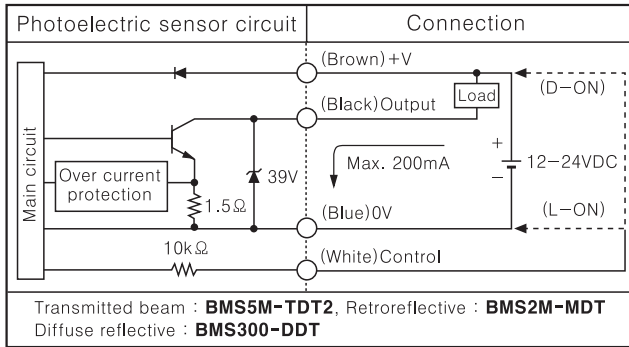

●PNP open collector output

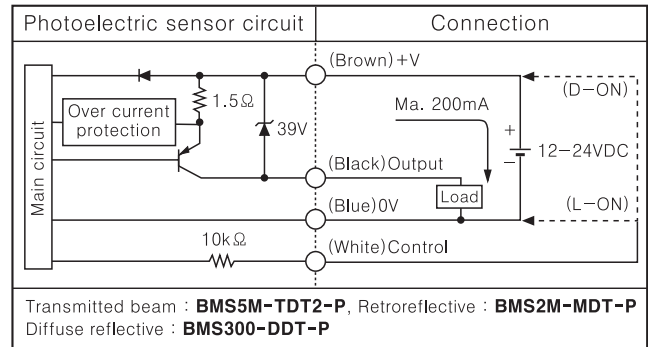

※Light ON / Dark ON mode selectable by control wire(White) [Light ON : Connect control wire to 0V
Dark ON : Connect control wire to +V

Operation mode

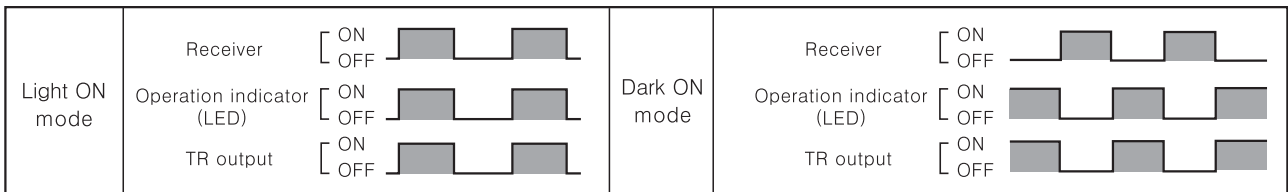

Connections

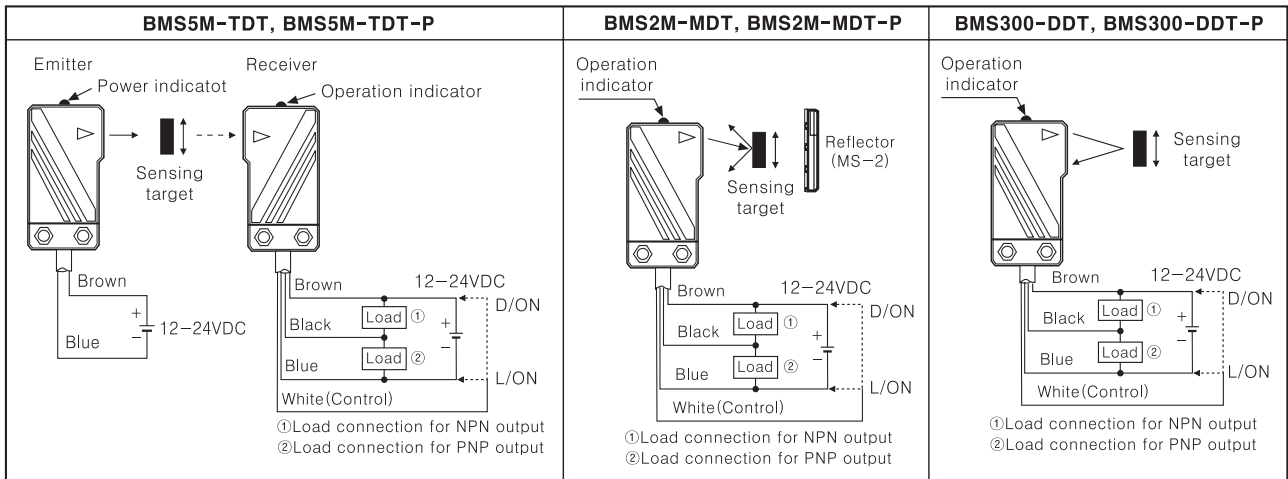

※Dark ON mode is on when control line is opened.

Dimensions

●Product

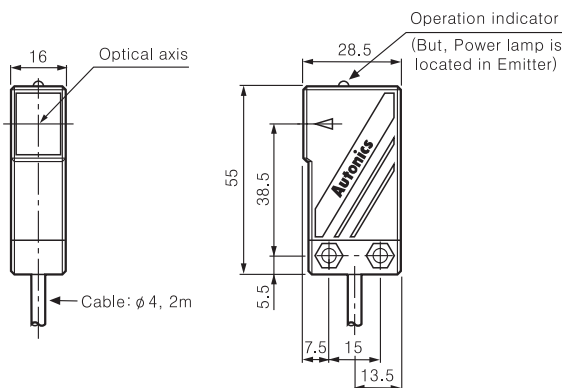

●Bracket

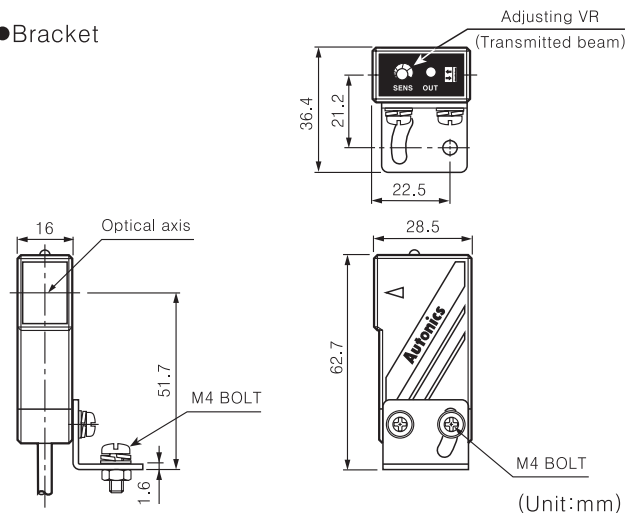

Side Sensing Type with Built-in Amplifier

● Reflector

<MS-2 >

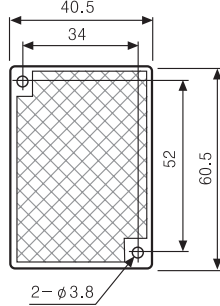

<MS-5 >

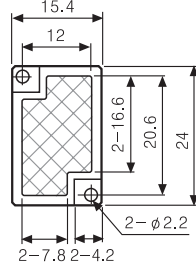

● Bracket

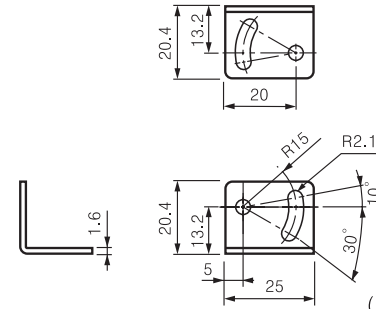
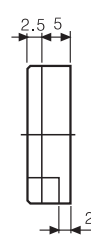

(Unit:mm)

■ Mounting and sensitivity adjustment

Please supply the power to the sensor, after set the emitter and the receiver facing each other and then adjust an optical axis and the sensitivity as follow :

◎ Optical axis adjustment

1. Transmitted beam type

Set the photoelectric sensor in the middle of the operation range of indicator adjusting the receiver or emitter right and left, up and down.

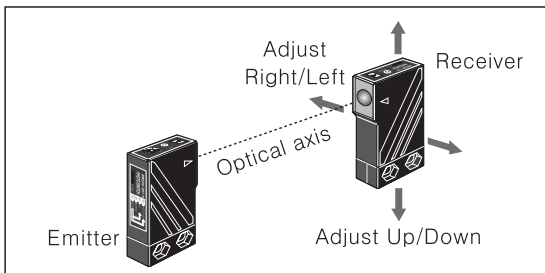

2. Retroreflective type

Mount the photoelectric sensor and reflector face then fix them in the middle of operation range of indicator adjusting the reflector right and left, up and down.

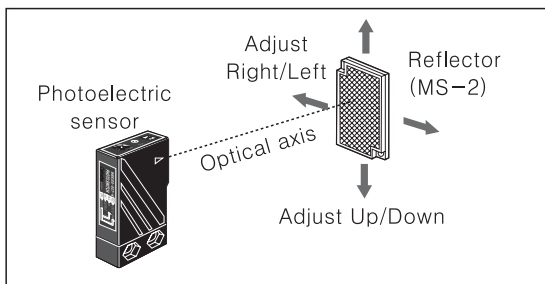

3. Diffuse reflective type

Mount the photoelectric sensor and the target then fix them in the middle of operation range of indicator adjusting the photoelectric sensor right and left, up and down.

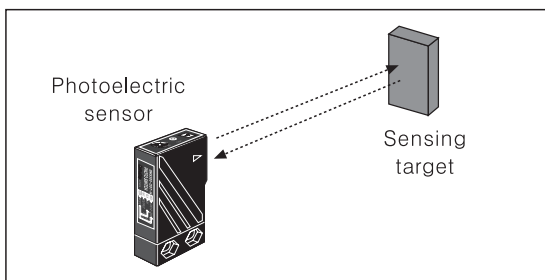

◎ Sensitivity adjustment

1. Retroreflective type

Fix the adjuster at max. position and then check if the sensor operate normally to pass the target within sensing area of the sensor.

If the sensor does not work normally by noise or external shine, turn the adjuster slowly up to the position .

※If reflectance of target is higher than non-glossy white paper, it might cause malfunction by reflection from the target when the target is near to photoelectric sensor.

Therefore enough space between the target should be used and photoelectric sensor or the surface of target should be mounted at an angel of 30° ~45° against optical axis.

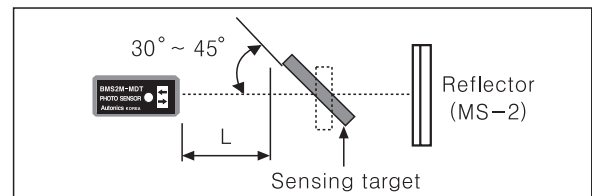

※If the mounting place is too small, please use MS-5 instead of MS-2 for same sensing distance.



2. Diffuse reflective type

Set the target at a position to be detected by the beam, then turn the adjuster until position (a) where the indicator turns on from min. position of the adjuster up to position (a) which the indicator turn on from min. Take the target out of the sensing area, then turn the adjuster until position (b) where the indicator turns on.

If position (b) is not checked, position (b) is the max. position. Set the adjuster in the middle of two switching position (a), (b).

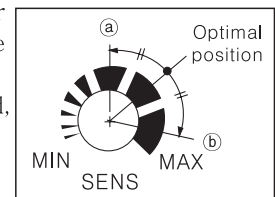

※Please be aware not to make the unstable operation of sensor by background and mounting side.

(A) Counter

(B) Timer

(C) Temp. controller

(D) Power controller

(E) Panel meter

(F) Tacho/ Speed/ Pulse meter

(G) Display unit

(H) Sensor controller

(I) Switching power supply

(J) Proximity sensor

(K) Photo electric sensor

(L) Pressure sensor

(M) Rotary encoder

(N) Stepping motor & Driver & Controller

(O) Graphic panel

(P) Production stoppage models & replacement