

# Incremental $\phi$ 40mm Shaft/Hollow Shaft/Built-in Type

## Diameter $\phi$ 40mm Shaft type/Hollow type/Built-in type Incremental Rotary encoder

### Features

- Easy installation at narrow space
- Small rotor inertia
- Power supply :  
5VDC, 12-24VDC  $\pm$ 5%
- Various output types

**!** Please read "Caution for your safety" in operation manual before using.



### Ordering information

E40	H	8	5000	3	N	24	
-----	---	---	------	---	---	----	--

Series	Shaft type	Hollow type	Pulse/1 Revolution	Output phase	Output	Power supply	Cable
S: Shaft type H: Hollow type HB: Hollow built-in type	External	Inner	Refer to resolution	2: A, B 3: A, B, Z 4: A, $\bar{A}$ , B, $\bar{B}$ 6: A, A, B, $\bar{B}$ , Z, $\bar{Z}$	T: Totem pole output N: NPN open collector output V: Voltage output L: Line driver output(*)	5 : 5VDC $\pm$ 5% 24: 12-24VDC $\pm$ 5%	No mark: Normal type (*) C: Cable outgoing connector type
	6: $\phi$ 6mm 8: $\phi$ 8mm	6: $\phi$ 6mm 8: $\phi$ 8mm 10: $\phi$ 10mm 12: $\phi$ 12mm					

\*Standard : E40S6-[PULSE]-3-N-24  
E40H8-[PULSE]-3-N-24  
E40HB8-[PULSE]-3-N-24

\*Standard: A, B, Z \*The power of Line driver is only for 5VDC

\*Cable length : 250mm

### Specifications

Item	Diameter $\phi$ 40mm shaft type of Incremental rotary encoder		
Resolution(P/R)	(Note1)	*1, *2, *5, 10, *12, 15, 20, 23, 25, 30, 35, 40, 45, 50, 60, 75, 100, 120, 150, 192, 200, 240, 250, 256, 300, 360, 400, 500, 512, 600, 800, 1000, 1024, 1200, 1500, 1800, 2000, 2048, 2500, 3000, 3600, 5000 (Not indicated type is available to customize)	
Electrical specification	Output phase	A, B, Z phase (Line driver : A, $\bar{A}$ , B, $\bar{B}$ , Z, $\bar{Z}$ phase)	
	Phase difference of output	Phase difference between A and B : $\frac{T}{4} \pm \frac{T}{8}$ (T=1 cycle of A phase)	
	Control output	Totem pole output	• Low $\Rightarrow$ Load current: Max. 30mA, Residual voltage : Max. 0.4VDC • High $\Rightarrow$ Load current: Max. 10mA, Output voltage (Power supply 5VDC): Min. (Power supply-2.0)VDC, Output voltage (Power supply 12-24VDC): Min. (Power supply-3.0)VDC
		NPN open collector output	Load current : Max. 30mA, Residual voltage : Max. 0.4VDC
		Voltage output	Load current : Max. 10mA, Residual voltage : Max. 0.4VDC
		Line driver output	Low $\Rightarrow$ Load current : Max. 20mA, Residual : Max. 0.5VDC High $\Rightarrow$ Load current : Max. -20mA, Output voltage : Min. 2.5VDC
	Response time (Rise/Fall)	Totem pole output	Max. 1 $\mu$ s
		NPN open collector output	Max. 1 $\mu$ s
		Voltage output	Max. 1 $\mu$ s
		Line driver output	Max. 0.5 $\mu$ s
	Max. Response frequency	300kHz	
	Power supply	• 5VDC $\pm$ 5% (Ripple P-P: Max. 5%) • 12-24VDC $\pm$ 5% (Ripple P-P: Max. 5%)	
	Current consumption	Max. 80mA (disconnection of the load), Line driver output: Max. 50mA (disconnection of the load)	
Insulation resistance	Min. 100M $\Omega$ (at 500VDC mega)		
Dielectric strength	750VAC 50/60Hz for 1 minute (Between all terminals and case)		
Connection	Cable outgoing type, 200mm cable outgoing connector type		
Mechanical specification	Starting torque	Shaft Type : Max. 40gf $\cdot$ cm (0.004N $\cdot$ m), Hole Type : Max. 50gf $\cdot$ cm (0.005N $\cdot$ m)	
	Rotor inertia	Max. 40g $\cdot$ cm <sup>2</sup> (4 $\times$ 10 <sup>-6</sup> kg $\cdot$ m <sup>2</sup> )	
	Shaft loading	Radial : Max. 2kgf, Thrust : Max. 1kgf	
	Max. allowable revolution	(Note2)	5000rpm
Vibration	1.5mm amplitude at frequency of 10 ~ 55Hz in each of X, Y, Z directions for 2 hours		
Shock	Max. 50G		
Ambient temperature	-10 ~ 70 $^{\circ}$ C (at non-freezing status), Storage: -25 ~ 85 $^{\circ}$ C		
Ambient humidity	35~85%RH, Storage: 35~90%RH		
Protection	IP50 (IEC standard)		
Cable	$\phi$ 5mm, 5P, Length : 2m, Shield cable (Line driver output : $\phi$ 5mm, 8P)		
Accessory	• Shaft type: $\phi$ 6mm coupling standard, $\phi$ 8mm coupling (Sold separately) • Hole type : Bracket		
Unit weight	Approx. 160g		
Approval	CE (Except for Line driver output)		

※ (Note1) '1\*' pulse is only for A, B phase (Line Driver output is for A,  $\bar{A}$ , B,  $\bar{B}$  phase)

※ (Note2) Max. allowable revolution  $\geq$  Max. response revolution [Max. response revolution (rpm) =  $\frac{\text{Max. response frequency}}{\text{Resolution}} \times 60 \text{ sec}$ ]

- (A) Counter
- (B) Timer
- (C) Temp. controller
- (D) Power controller
- (E) Panel meter
- (F) Tacho/Speed/Pulse meter
- (G) Display unit
- (H) Sensor controller
- (I) Switching power supply
- (J) Proximity sensor
- (K) Photo electric sensor
- (L) Pressure sensor
- (M) Rotary encoder
- (N) Stepping motor & Driver & Controller
- (O) Graphic panel
- (P) Production stoppage models & replacement

# E40 Series

## Control output diagram

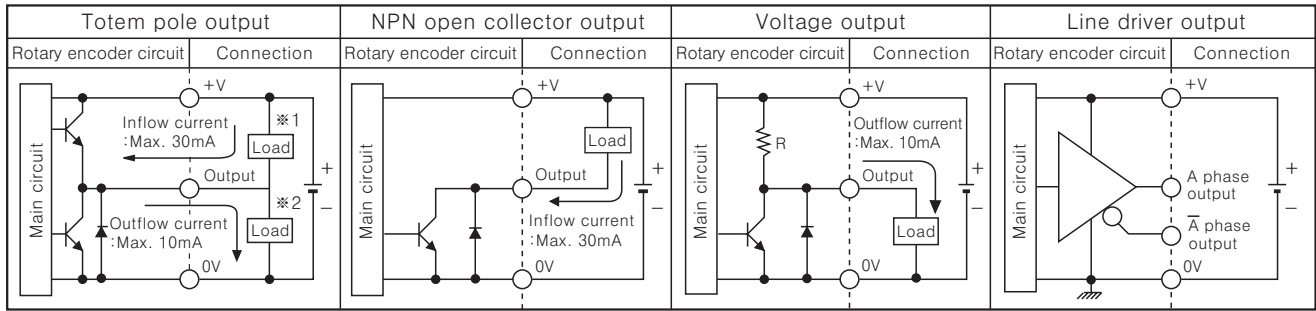

※ Totem pole output type can be used for NPN open collector output type(※1) or Voltage output type(※2).  
 ※ All output circuits of A, B, Z phase is same. (Line driver output is A,  $\bar{A}$ , B,  $\bar{B}$ , Z,  $\bar{Z}$ )

## Output waveform

- Totem pole output / NPN open collector output / Voltage output
- Line driver output

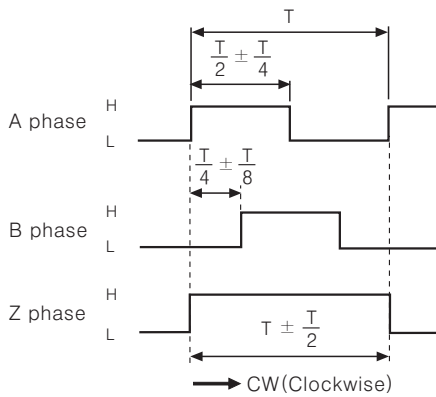

※ CW : As viewed from the shaft

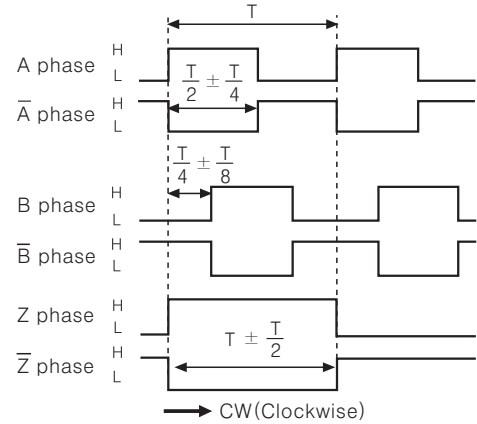

## Connections

### Normal type

- Totem pole output / NPN open collector output / Voltage output

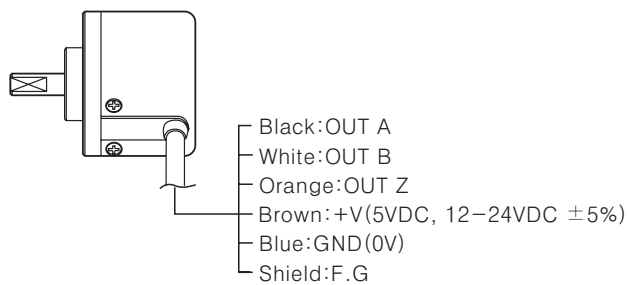

- ※ Unused wires must be insulated.
- ※ The metal case and shield wire of encoder should be grounded(F.G).

### Line driver output

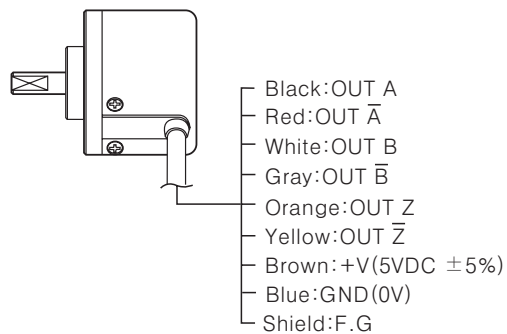

### Cable outgoing connector type

- Totem pole output / NPN open collector output / Voltage output
- Line driver output



Totem pole output NPN open collector output Voltage output			Line driver output		
Pin No	Function	Cable color	Pin No	Function	Cable color
①	OUT A	Black	①	OUT A	Black
②	OUT B	White	②	OUT $\bar{A}$	Red
③	OUT Z	Orange	③	+V	Brown
④	+V	Brown	④	GND	Blue
⑤	GND	Blue	⑤	OUT B	White
⑥	F.G	Shield	⑥	OUT $\bar{B}$	Gray
			⑦	OUT Z	Orange
			⑧	OUT $\bar{Z}$	Yellow
			⑨	F.G	Shield

※ F.G(Field Ground): It should be grounded separately.

# Incremental $\phi$ 40mm Shaft/Hollow Shaft/Built-in Type

## Dimensions

### Normal type

#### Shaft type

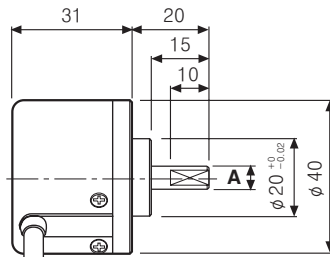
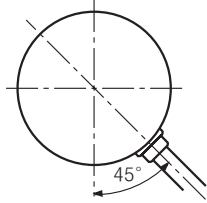

A	Tolerance
$\phi$ 6	-0.01 -0.015
$\phi$ 8	-0.01 -0.02

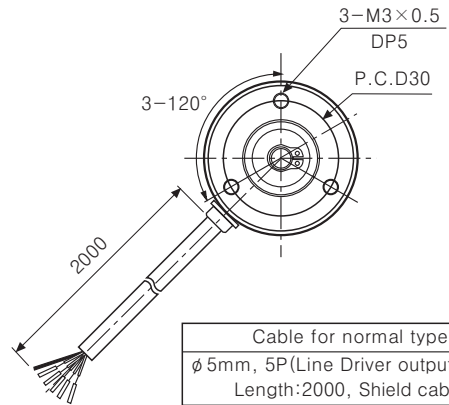

Cable for normal type  
 $\phi$  5mm, 5P (Line Driver output : 8P),  
 Length: 2000, Shield cable

(Unit:mm)

#### Hollow shaft / Hollow shaft built-in type

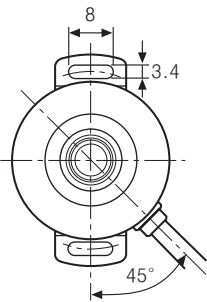

E40H

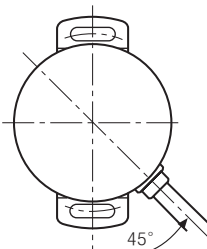

E40HB

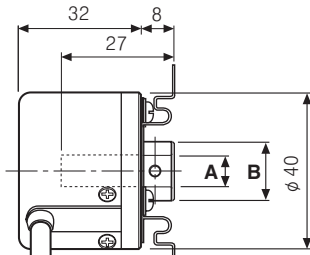
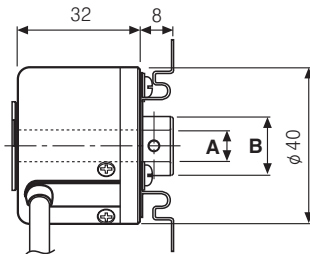

A	$\phi$ 6	$\phi$ 8	$\phi$ 10	$\phi$ 12
B		$\phi$ 15	$\phi$ 17	
Tolerance			+0.015 -0	

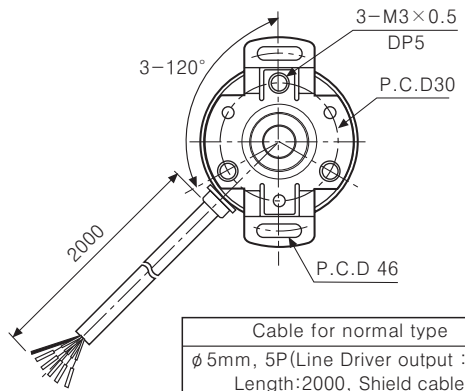

Cable for normal type  
 $\phi$  5mm, 5P (Line Driver output : 8P),  
 Length: 2000, Shield cable

### Cable outgoing connector type

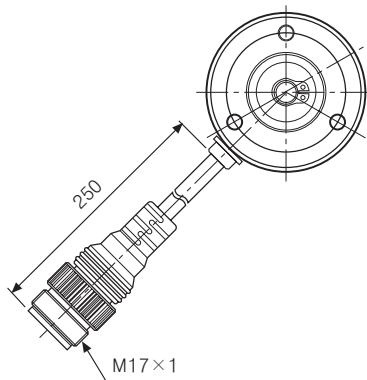

※Connector cable is customizable and see M-46 for specifications.

#### Bracket

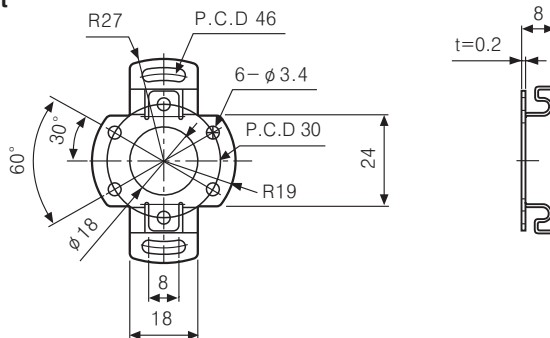

#### Coupling(E40S)

##### $\phi$ 6 Coupling

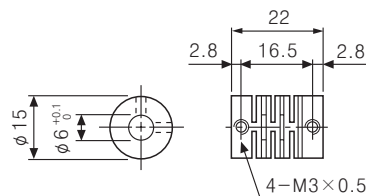

##### $\phi$ 8 Coupling

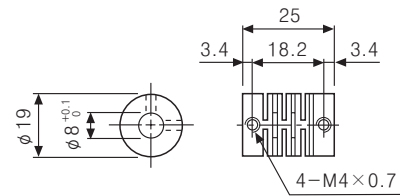

(A) Counter

(B) Timer

(C) Temp. controller

(D) Power controller

(E) Panel meter

(F) Tacho/Speed/Pulse meter

(G) Display unit

(H) Sensor controller

(I) Switching power supply

(J) Proximity sensor

(K) Photo electric sensor

(L) Pressure sensor

(M) Rotary encoder

(N) Stepping motor & Driver & Controller

(O) Graphic panel

(P) Production stoppage models & replacement